

HAND-HELD DIAMOND CORE DRILL

DF-320



Comes with Toolbox

JDPower - model	DF-320
Current	6.2 A
Power	1350W
Speed (variable)	0-2200 rpm
Drilling size range	20 - 76 MM (1"~3")
Machine weight	4 kg
*Toolbox Included	
½" BSP Male and 1¼" BSP Male fittings	

- **Options** – CHUCK ADAPTER, WATER COLLECTOR
- **Toolbox** – 27mm adjustable wrench, 1 ¼" spindle adapter, 1 ¼" wrench.

DF-320



DF320 with Optional Water Collector



Optional Chuck adapter



Optional Water Collector

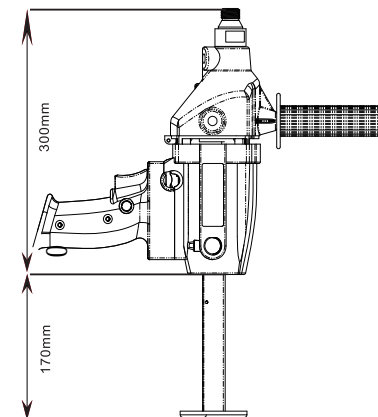
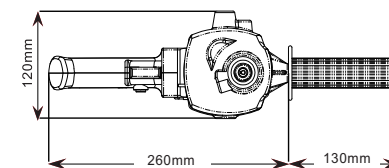

1. Patented **telescopic support arm** - makes drilling safer and more comfortable "lean into" or "rest on" the arm using your body weight, not your back!
2. **Powerful 1350W** motor
3. **Safety Features** - protect Operator against cut electrical cables:
 - Double insulation on motor
 - Insulated handle
 - Insulated telescopic arm
 - Earth Leakage trip switch
4. **Motor overload protector** - protects motor and gearbox extending the life of the drill
5. **Slip-Clutch** - Protects motor, gearbox and Operator if core bits jam. Clutch is easily adjustable to extend the life of the core drill.
6. **Variable speed trigger** - for greater operator control.
7. **Soft start** - extends the life of the gearbox and motor
8. **Compact design** - weights only **4 kg**.
9. Comes with **case** and **tools**.